

• **Carretillas elevadoras**

• **Forklifts** • **Chariots elevateurs**

Modelos • **Models** • **Modèles**

• **TH - 300**



Dimensiones • **Dimensions** • **Dimensions**

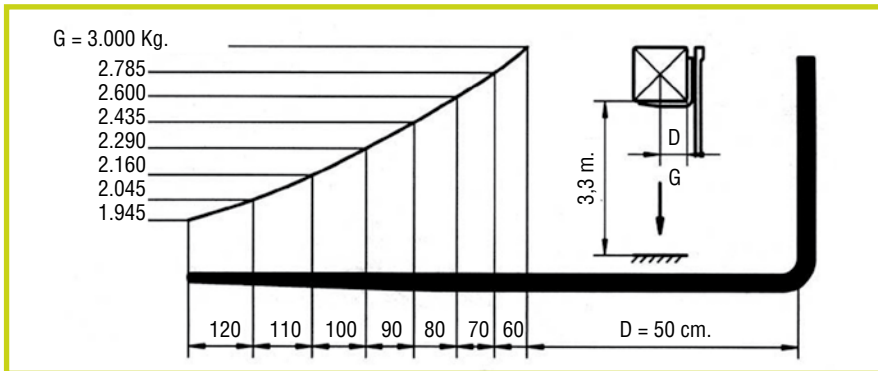

TH - 300	
H1	2.310
H2	Dúplex 3,60 m.: 2.515
	Tríples 4,50 m.: 2.295
	Tríples 5 m.: 2.505
	Tríples 6 m.: 2.855
H3	230
L1	1.765
L2	1.800
L3	4.315
L4	1.830

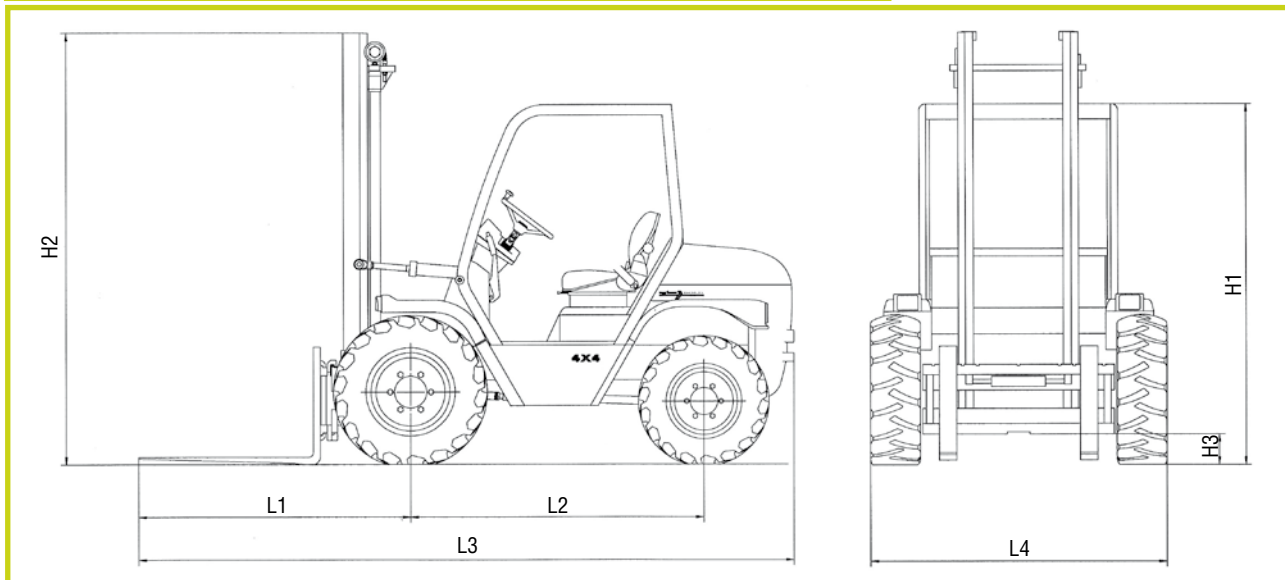

• TH - 300 • Carretillas elevadoras • Forklifts • Chariots elevateurs

Características Técnicas • Technical Features • Caracteristiques Techniques



MOTOR	Deutz 4 cilindros, Refrigerado por aire, 60 C.V.
CAPACIDAD Kg.	3.000
TRANSMISIÓN	Hidrostática Rexroth.
TRACCIÓN	4 x 4 con desconector electrohidraulico.
VELOCIDAD	24 Km/h. Sistema de aproximación lenta.
FRENOS	Hidrostático a las 4 ruedas, De servicio a las ruedas delanteras, de estacionamiento a las ruedas
RUEDAS	delanteras.12,0/75-18
PESO Kg.	4.300
PENDIENTE SUP.	38 %
OPCIONES MÁSTIL m.	Dúplex - Triplex
RADIO DE GIRO mm.	Exterior: 4.150 / Interior: 1.750



MOTOR	Deutz 4 cylinders, Air cooled, 60 C.V.
CAPACITY Kg.	3.000
TRANSMISSION	Hydrostatic Rexroth with variable flow.
TRACCIÓN	4 x 4 with electrohydraulic disconnection.
SPEEDS	Slow and fast: 0 - 24 Km/h, Inching Pedal.
BRAKES	Hydrostatic for 4 wheels, Service Brakes: Acting front wheels.Parking: Mechanic on front axle.
WHEELS	12,0/75-18
WEIGHT Kg.	4.300
SURMONTABLE SLOPE	38 %
OPTIONS MAST m.	Dúplex - Triplex.
TURNING RADIUS mm.	External: 4.150 / Internal: 1.750



MOTEUR	Deutz 4 cylindres , Refroidissement par air, 60 C.V.
CAPACIDAD Kg.	3.000
TRANSMISSION	Hydrostatique Rexroth avec débit variable.
TRACTION	4 x4 avec déconnectateur electrohydraulique.
VITESSES	Lent et rapid: 0 - 24 Km/h, Système approche lente.
FREINS	Hydrostatic a les 4 roues, Frein de Service: Sur le front roues Frein de stationnement: Sur l'arbre de transmission pont avant.
ROUES	12,0/75-18
POIDS Kg.	4.300
INCLINATION SURMONTABLE	38 %
OPTIONS MÂT m.	Dúplex - Triplex
RAYON DE BRACAGE mm.	Exterieur: 4.150 / Interieur: 1.750