

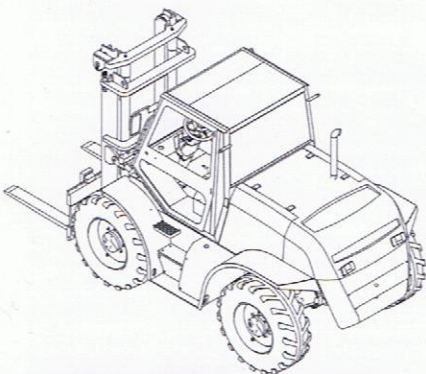

## HEAVY DUTY ROUGH TERRAIN FORKLIFT TRUCKS – 40 DR, 50 DR, 70 DR

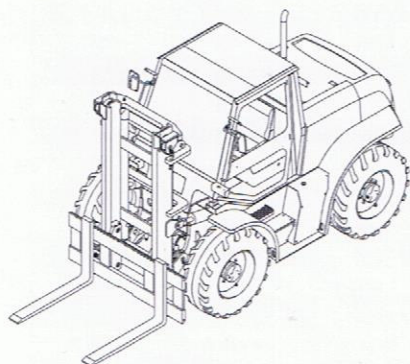

IPO Lifts rough terrain forklifts are a reliable and versatile solution. Ranging from 4 to 8 tones lifting capacity, they are distinguished with productivity and security for all types of cargo handling on difficult and irregular terrain. With a greater turning radius and supplied with both front and back driving axels the forklifts ensure high maneuverability and superb productivity in rough terrain areas. The wide range of off road 4x4 models are perfect for virtually any rehandling environment from docks to yards, mines, timber forestry, construction sites and builders' merchants.

- Open mines
- Military
- Agriculture
- Woodwork enterprises
- Deserts and sand regions
- Underdeveloped road conditions

### Core Technologies and Components

Engine Perkins 1104D-44T	Diesel, 4 cylinders in-line, 4 stroke, 4400 cm3, direct injection, water cooled
Transmission DANA T12000	Hydrodynamic with torque convertor and full Power Shift
Mast type	A robust produced simplex mast of all roller construction – duplex and triplex option available
Drive axle DANA	Wet disk brakes in oil bath without service with differential lock
Drive steering axle DANA	Wet disk brakes in oil bath without service

**HIGH PERFORMANCE**

**4x4**

- Full hydrostatic power steering
- Overhead guard
- Closed cabin with heater and AC
- Adjustable Grammer Primo XL seat
- Full safety equipment according to ROPS & FOPS Standard