



**GABELSTAPLER  
TH - 175 C**

## EIGENSCHAFTEN

<b>MOTOR</b>	Perkins 4 Zylinder wassergekühlt; 31,7 Kw.
<b>NUTZLAST</b>	1.700.
<b>GETRIEBE</b>	Hydrostat RexRoth.
<b>ANTRIEB</b>	4x4 mit Sicherheitskupplung electrohydraulisch.
<b>GESCHWINDIGKEITEN</b>	1. Gang 0-9 Km/h • 2. Gang 0-22 Km/h
<b>BREMSEN</b>	Hydrostatisch über vier räder.
<b>BEREIFUNG</b>	10,0/75-15,3 • 6,50-16
<b>LEERGEWICHT</b>	2.735 Kg.
<b>STEIGFÄHIGKEIT</b>	38 %
<b>MAST-OPTIONEN</b>	Duplex - Triplex Hubmasten.



G = 1.700 Kg.

1.555  
1.410  
1.275  
1.165  
1.105  
900

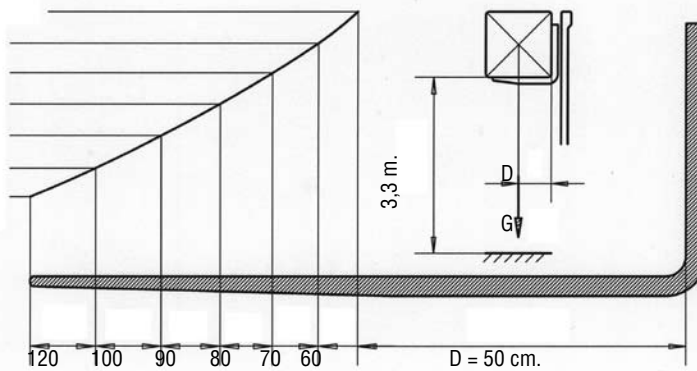

TH - 175 C	
<b>H1</b>	2.065
<b>H2</b>	Duplex 2,50 m.: 1.950 mm. Duplex 3,14 m.: 2.250 mm. Duplex 3,60 m.: 2.480 mm. Triplex 4,00 m.: 2.050 mm. Triplex 6,00 m.: 2.820 mm.
<b>H3</b>	200 mm.
<b>L1</b>	1.760 mm.
<b>L2</b>	1.600 mm.
<b>L3</b>	3.950 mm.
<b>L4</b>	1.300 - 1.400 mm.

